



## Installation Instructions

# H6001

## KW/KWH Transducer

**VERIS INDUSTRIES**

PORTLAND, OREGON USA  
 (503) 598-4564 FAX (503) 598-4664  
 1-800-354-8556

<http://www.veris.com> email:sales@veris.com



## OPERATION

### Easy installation

- Small size (9.50" X 8.25" x 4.0") fits directly in most panel enclosures.
- Conduit ready enclosure for external mounting. Hinged panel door.
- Direct voltage connection up to 600 VAC--no expensive potential transformers (PTs)
- Powered by voltage inputs
- Easy field voltage selection (120 to 600 VAC)
- 4-20 mA output loop continuity LED
- Pulse output rate LED

### Accurate analog and pulse outputs

- Accurate to +/- 0.5% of reading..true RMS power!
- 4-20 mA output for demand kW
- Pulse output for kWh...adjustable rate compatible with all automation systems and data loggers.
- Phase loss/reversal/low voltage alarm output to protect valuable equipment
- kW and/or kWh display options. Maintains readings in event of power loss

### SAFE CTs...eliminates need for costly CT shorting bars

- Current transformers (CTs) utilize accurate 1.0V output... non hazardous, even if left unshorted!
- Eliminates need for current shorting bars
- Choose from split-core or solid-core CTs
- CT accuracy  $\pm 1\%$  from 10% to 100% of the rating

### Applications

- Energy management & performance contracting
- Submetering for commercial tenants
- Departmental costing in manufacturing facilities
- Power monitoring for tool wear and process control

The H-6001 series 3-phase power (KW) transducer is designed for use in industrial, commercial, and building automation kW and kWh applications.

The H-6001 accepts three Veris 1.0 V current transformer inputs and three direct connect voltage inputs. The transducer multiplies the input current signal, voltage input, and power factor for each phase to calculate true RMS power ( $kW = E \times I \times 1.732 \times \text{power factor}$ ). The instantaneous power (kW) of all three phases is summed and converted to an industry-standard 4-20 mA output signal for use in demand management (load shedding) applications. The sensor also accumulates this instantaneous value over time and produces a pulsed output proportional to the energy usage (kWh). The frequency of the output pulses is proportional to the total power consumed and can be used to measure energy usage for an entire building, selected area, or individual loads (chillers, compressors, etc..).



**WARNING: REFER SERVICING TO QUALIFIED PERSONNEL ONLY!**

- This product is not intended for life or safety applications
- Potential electrocution hazard exists. Installing sensors in an energized motor control center or on any energized conductor can be hazardous.
- Read instructions thoroughly prior to installation

*Severe injury or death can result from electrical shock during contact with high-voltage conductors or related equipment. Disconnect and lock-out all power sources during installation and service. Applications shown are suggested means of installing this equipment, but it is the responsibility of the installer to ensure that the installation is in compliance with all national and local codes. Installation should be attempted only by individuals familiar with all applicable codes, standards, and proper safety procedures for high-voltage installations.*

# GENERAL WIRING DIAGRAM

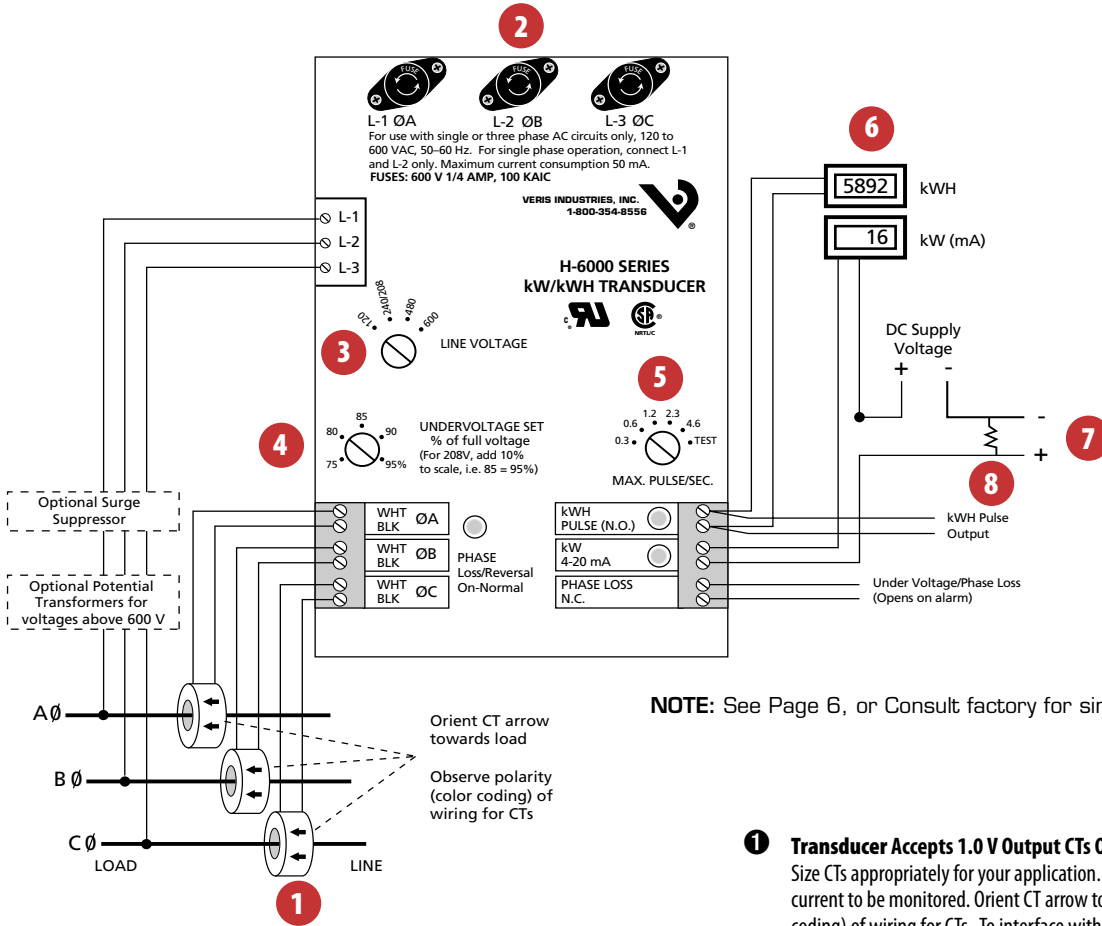

NOTE: Use with potential transformers has not been evaluated by UL

NOTE: See Page 6, or Consult factory for single phase installation



## IMPORTANT INSTALLATION NOTES

- This unit accepts 1.0V full-scale output Current Transformers (CTs) only. DO NOT USE 0-5A OUTPUT CURRENT TRANSFORMERS (e.g., 200:5 type CTs) without H-6902B adapter(s). Consult factory for further information.
- Secure unit by bolt and nut or use a padlock to discourage unauthorized access and minimize potential electric shock hazard.

- 1 Transducer Accepts 1.0 V Output CTs Only!**  
Size CTs appropriately for your application. CT rating must be greater than maximum current to be monitored. Orient CT arrow towards load per label. Observe polarity (color coding) of wiring for CTs. To interface with 5A output CTs, consult factory for H-6902B adapters.
- 2 Mandatory Fuse or Breaker per NEC**  
Max. transducer current draw is 50 mA. Installer must ensure circuit interrupters are installed in compliance with local and national codes (fuse rating 100 KAIC min.).
- 3 Line Voltage Selector**  
Set to match line to line voltage to be monitored **before power is applied to meter.**
- 4 Undervoltage Set-point**  
Phase loss relay terminals open when voltage falls below indicated percentage of the **voltage shown on the line selector switch.**
- 5 kWh Consumption Pulse Rate Selection**  
Sets maximum pulse output rate at full power. Set for desired rate (compatible with your automation system.)
- 6 Optional kW/kWh Displays**  
See OPTIONAL DISPLAYS section on page 8.
- 7 kW Demand Analog 4-20 mA Output**  
Provides instantaneous kW analog output for connection to automation system. **Requires external 12- 24 VDC supply.**
- 8 Install Resistor for kW Voltage Output**  
For automation systems requiring a voltage rather than current kW analog output, install appropriately sized resistor as shown.

# INSTALLATION

## 1. Transducer Mounting and Setup

Locate transducer within 30' of current transformers, in an area accessible only to qualified service personnel. Transducer and/or enclosure should be mounted using #10 screws. Unit is intended for dry locations, indoor use only. The enclosure should be secured with a padlock or nut and bolt.

Set the MAX. PULSE/SEC. Ⓜ switch to the test position and adjust the UNDERVOLTAGE SET Ⓜ knob fully counterclockwise to the 75% position.

## 2. Set Voltage Selection Switch to the Correct Line-to-Line Voltage



### DO NOT CONNECT VOLTAGE INPUTS LIVE!

Avoid the danger of electric shock. Do not make connections while power is on. The transducer may also be damaged by this practice.

Wires used to connect the transducer are normally 14 AWG. Terminals will accept 14-26 AWG. Wire strip length is .236" (6mm). Recommended tightening torque 4.5 in. lbs.

If applied voltage exceeds 600 VAC, you will need to use appropriately sized external potential transformer(s). Consult Factory.



### Voltage connections to the transducer require fuses or circuit breakers per NEC. Fusing is mandatory.

(Current draw of unit is less than 50 mA). **NOTE:** Fuses are to be rated 100 KAIC min. Sources capable of delivering more than 100KA interrupt current may require alternate fusing. Always ensure fusing complies with local and national electrical codes.

## 3. Voltage Connections

Ensure that the circuit power is off and connect the three voltage inputs from the supply legs to the transducer voltage inputs one at a time. After connecting all three phase voltages, turn the power on and verify that the PHASE Loss/Reversal On-Normal LED is illuminated. If the LED lights, then the voltage wires are hooked up correctly. If the light is not on, the phasing is incorrect. This condition should be corrected before connecting the current transformers.

To correct the phasing, turn the power off and reverse the position of the A and C voltage connections at the transducer. Turn the power on, and verify that the PHASE Loss/Reversal LED is illuminated. If the LED does not light up, check the UNDERVOLTAGE SET knob, to assure that the setpoint is not below the actual line-to-line voltage applied to the transducer. Try increasing the setting to the 95% position. If the PHASE LED still will not light, consult the troubleshooting guide on page 4, or contact factory technical support via e-mail, or by telephone, at the numbers listed on the front page of this document.

## 4. Current Transformer (CT) Installation

Ensure that power to the load is off. Connect and verify the connection of the CTs one at a time. Insure that the CTs are connected in the same sequence as the actual voltage connections, where L-1 and phase A are associated with the same supply wiring. Clamp the phase "A" CT around the "L-1" supply wire with the arrows on the CT label pointing towards the load, connect the CT wiring to the ØA terminals of the transducer, per the labeling and turn the power on. The kWh pulse LED should flash and the kW display (if equipped) should show an increase (with no CT's hooked up the display will read "0"). If the PULSE LED does not flash and the kW display (if equipped) does not show an increase, the phasing of the CT is incorrect. This must be corrected before connecting the remaining two CTs to simplify troubleshooting.

Incorrect phasing of the CT can be caused by one of two things: either the CT is on the wrong supply wire(s) or it is not correctly orientated to the load.

Z101187-0B

Turn the system power off and reorient the CT by reversing the black and white wires at the transducer terminal block, or turning the CT over. Turn the power on. If the kWh pulse light is not flashing and the kW output does not show an increase, turn the power off and put the CT on a different supply wire. Repeat the above procedure until the kWh pulse light flashes and kW output current increases.

The kWh pulse light should blink faster each time a CT is added indicating an *increase* in measured power.

Ensure that the power is off and put the second CT on phase B and verify that the kWh light is blinking faster and the kW display shows an increase. If this does not occur reorient the CT until the desired results are achieved.

Connect the final CT and verify that the kWh pulse light is blinking faster and the kW output *increases*.

## 5. Connect Outputs To Automation System

kW (demand) output connection is non-polarity sensitive. External power (DC voltage) must be supplied as shown at Ⓜ (note if DC voltage is not readily available at time of start-up, two 9V batteries in series can be used to check operation).

Wire kWh pulse output to controller (This is not a load switching output — see ratings in specifications).

## 6. Power Unit (Turn on Load to be Monitored)

kW 4-20 mA Loop continuity LED should light (IF LOOP IS CONNECTED).

kWh pulse LED will blink at regular intervals.

## 7. Adjust the Undervoltage Set to Desired Level

The UNDERVOLTAGE SET Ⓜ knob allows you to set an alarm level for low voltages situations. If it is set at 85% that means that it will provide an alarm output if the voltage drops by 15% from the selected LINE VOLTAGE. **NOTE: these percentages relate to the voltage indicated on the LINE VOLTAGE selector switch, e.g. if the transducer is connected to 208 volts, the 80% position will actually trip at 92% of 208 volts – (20% below 240 volts).**

## 8. Select kWh Max. Pulse Rate (if used)

Veris' handy pulse rate selector switch lets you choose the pulse rate compatible with your automation system – regardless of voltage setting. The rate shown on the MAX. PULSE/SEC Ⓜ switch is approximately the rate produced at full load. The rates shown correspond to Tables 2 and 3 on page 5, and are offset from the values calibrated in the H6001 for ease of setup. If you will be back-calculating pulse values, check Table 4 (p. 5) for the actual calibration values.

## 9. Determine kWh/Pulse for Programming Your Automation Panel

**EASY METHOD:** Refer to TABLE 2 on page 5 – if your application uses the voltages and CT sizes shown in the table and no external potential transformers. **NOTE:** for 208 volt operation use the 240 volt table and use the value of 240 volts in all calculations.

**kWh/Pulse =**

**METHOD B:** Calculate as shown below:

$$\frac{(\text{WH/Pulse}) \times \text{I} \times \text{PT Ratio (if used)}}{1000}$$

$$\text{kWh} = \text{kWh/Pulse} \times \text{Pulse Count (consumption)}$$

**Where:**

**WH/Pulse** = Value from table 3 (page 5)

**I** = Maximum rated full scale value of one CT (in amps)

**Pulse Count** = Accumulated pulses over a period of time

**PT Ratio** = Potential Transformer primary voltage divided by its secondary voltage

**NOTE: One pulse is defined as both a rising and falling edge, i.e.** 

## INSTALLATION CONTINUED

### 10. Determine kW Value for Programming Your Automation Panel

See Table 1, or use formula below

$$\text{kW MAXIMUM} = \frac{E \times I \times \sqrt{3}}{1000}$$

$$\text{kW DEMAND} = (\text{kW MAXIMUM}) \left( \frac{\text{mA out} - 4}{16} \right)$$

**Where:**

- E** = Line-to-line voltage selected on the meter\*
- I** = Maximum rated full scale of one CT in amps
- mA out** = 4-20 mA reading
- $\sqrt{3}$  = approximately 1.732 (factor for 3 phase system vector)

\*e.g., When the voltage selection switch is in the 208/240 position, always use 240 for the calculation.

### 11. Optional Quick Check of Outputs

- Calculate average of the three line currents (I avg.) with a portable clamp-on ammeter.
- Calculate the approximate kW:

$$= \frac{E \times I \text{ (avg.)} \times 1.732 \times \text{power factor (use 0.9 if unknown)}}{1000}$$

- Compare the calculated value with the actual 4-20 mA reading (Use kW DEMAND formula above)
- Calculate the approximate seconds per pulse (see TABLE 2 on page 5 for standard CTs up to 2400A, or TABLE 4):

$$\text{seconds per pulse} \approx \frac{\text{kW DEMAND} \times \text{Pulses per second maximum}}{\text{kW MAXIMUM}}$$

Pulses per second maximum is read from selection switch.

- Compare approximate seconds per pulse with the number of seconds between kW pulses as indicated by kWh PULSE LED on unit.

**NOTE:** The 6001 is very accurate. Since these calculations are approximate, there may be some variation. Also, calculations will vary if there are load changes during readings.

## TEST MODE

The TEST setting on the MAX PULSE/SEC. switch is used to verify operation of the power multiplication portion of the circuit, and also facilitates troubleshooting. When in the test mode, the pulse LED should blink steadily to indicate proper circuit operation. Since it accelerates the pulse output to 9.2 pulses/sec. at max load, you will be able to determine whether the unit is operating even when no load is present (voltage must be present – the unit is monitoring its own current draw).

TABLE 1: kW MAXIMUM

kW READING AT 20 mA (4 mA = 0 kW)

VOLTAGE SETTING	SINGLE CT SIZE in AMPS									
	50	100	150	200	300	400	600	800	1000	2400
600 V	51.96	103.9	155.9	207.8	311.8	415.7	623.5	831.4	1039.0	2494.0
480 V	41.57	83.14	124.7	166.3	249.4	332.6	498.8	665.1	831.4	1995.0
208/240V	20.78	41.57	62.35	83.14	124.7	166.3	249.4	332.6	415.7	997.7
120V	10.39	20.78	31.18	41.57	62.35	83.14	124.7	166.3	207.8	498.8

## TROUBLESHOOTING

**Problem:** Phase loss LED out.

**Solution:**

- On initial installation, check L-1, L-2, L-3 to ensure phases are not reversed, and that all are connected to the system voltage. Try swapping L-1 and L-3 to correct the phase rotation.
- Check that voltages on phases are above undervoltage set-point.
- Assure that the transducer is powered from an un-switched supply connection.

**Problem:** Pulse LED does not blink

**Solution:**

- Ensure monitored load is ON. Ensure fuse or breakers to transducer are not blown.
- Verify that CTs are all oriented towards load as indicated on label.
- Verify all CT wiring is correct (polarity of black/white must be observed) and that CTs are clamped around the proper supply wiring. Review installation instructions on page 3.

**Problem:** Transducer output indicates only a fraction of actual power consumption

**Solution:**

- Verify that CTs are all oriented towards load as indicated on label (arrows toward load).
- Verify all CT wiring is correct (polarity of black/white wires must be observed). Review CT installation instructions on page 3.
- Check that the current and voltage inputs have proper relationship (if voltage legs are reversed, Phase Loss LED will be out).

**Problem:** The phases are not clearly marked, or difficult to identify:

**Solution:**

- Make sure that there is power supplied to the load.
- Put the pulse selector switch in the test mode.
- Put jumpers on the phase B and C CT inputs of the transducer, and connect one of the CTs to the phase A input. The kWh pulse light will either be flashing or it will be off.
- If the light is flashing, reverse the wires and see if the light goes out. If the light goes out the CT is clamped onto the proper supply phase wire. Return the CT wiring to its original polarity.
- If the light is off when the connection is made, reverse the wires and see if the light starts flashing. If it does, the CT is on the correct phase. If not, clamp the CT to another supply wire, and repeat this step.
- Repeat steps "C" to "E" for each phase (e.g. put jumpers on phase A & C and connect a CT to phase B), and mark each CT for the correct phase.

**Problem:** kW DEMAND calculated from pulses (kWh) jumps rapidly and decays, or appears unstable with steady load.

**Solution:** The 4-20 mA (kW) signal should be used to provide an accurate measure of demand (kW). If demand is calculated from the pulses, each new pulse will cause a demand reading jump, particularly if the load is light (slow pulse rate). The 4-20 mA signal provides an accurate reading of instantaneous demand.

Table 2: QUICK REFERENCE PROGRAMMING TABLE

EXAMPLE: Max. desired pulse selection switch set to 2.3; using 70A CTs at 600 VAC, then each pulse = 0.00875 kWh

**600 VOLTS**

Pulses/SEC. Switch Set to:	20	30	50	70	100	150	200	300	400	600	800	1000	1600	2400
4.6	0.001250	0.001875	0.003125	0.004375	0.006250	0.009375	0.012500	0.018750	0.025000	0.037500	0.050000	0.062500	0.100000	0.150000
2.3	0.002500	0.003750	0.006250	0.008750	0.012500	0.018750	0.025000	0.037500	0.050000	0.075000	0.100000	0.125000	0.200000	0.300000
1.2	0.005000	0.007500	0.012500	0.017500	0.025000	0.037500	0.050000	0.075000	0.100000	0.150000	0.200000	0.250000	0.400000	0.600000
0.6	0.010000	0.015000	0.025000	0.035000	0.050000	0.075000	0.100000	0.150000	0.200000	0.300000	0.400000	0.500000	0.800000	1.200001
0.3	0.020000	0.030000	0.050000	0.070000	0.100000	0.150000	0.200000	0.300000	0.400000	0.600000	0.800000	1.000000	1.600001	2.400001

**480 VOLTS**

Pulses/SEC. Switch Set to:	20	30	50	70	100	150	200	300	400	600	800	1000	1600	2400
4.6	0.001000	0.001500	0.002500	0.003500	0.005000	0.007500	0.010000	0.015000	0.020000	0.030000	0.040000	0.050000	0.080000	0.120000
2.3	0.002000	0.003000	0.005000	0.007000	0.010000	0.015000	0.020000	0.030000	0.040000	0.060000	0.080000	0.100000	0.160000	0.240000
1.2	0.004000	0.006000	0.010000	0.014000	0.020000	0.030000	0.040000	0.060000	0.080000	0.120000	0.160000	0.200000	0.320000	0.480000
0.6	0.008000	0.012000	0.020000	0.028000	0.040000	0.060000	0.080000	0.120000	0.160000	0.240000	0.320000	0.400000	0.640000	0.960000
0.3	0.016000	0.024000	0.040000	0.056000	0.080000	0.120000	0.160000	0.240000	0.320000	0.480000	0.640000	0.800000	1.280001	1.920001

**240 VOLTS**

Pulses/SEC. Switch Set to:	20	30	50	70	100	150	200	300	400	600	800	1000	1600	2400
4.6	0.000500	0.000750	0.001250	0.001750	0.002500	0.003750	0.005000	0.007500	0.010000	0.015000	0.020000	0.025000	0.040000	0.060000
2.3	0.001000	0.001500	0.002500	0.003500	0.005000	0.007500	0.010000	0.015000	0.020000	0.030000	0.040000	0.050000	0.080000	0.120000
1.2	0.002000	0.003000	0.005000	0.007000	0.010000	0.015000	0.020000	0.030000	0.040000	0.060000	0.080000	0.100000	0.160000	0.240000
0.6	0.004000	0.006000	0.010000	0.014000	0.020000	0.030000	0.040000	0.060000	0.080000	0.120000	0.160000	0.200000	0.320000	0.480000
0.3	0.008000	0.012000	0.020000	0.028000	0.040000	0.060000	0.080000	0.120000	0.160000	0.240000	0.320000	0.400000	0.640000	0.960000

**120 VOLTS**

Pulses/SEC. Switch Set to:	20	30	50	70	100	150	200	300	400	600	800	1000	1600	2400
4.6	0.000250	0.000375	0.000625	0.000875	0.001250	0.001875	0.002500	0.003750	0.005000	0.007500	0.010000	0.012500	0.020000	0.030000
2.3	0.000500	0.000750	0.001250	0.001750	0.002500	0.003750	0.005000	0.007500	0.010000	0.015000	0.020000	0.025000	0.040000	0.060000
1.2	0.001000	0.001500	0.002500	0.003500	0.005000	0.007500	0.010000	0.015000	0.020000	0.030000	0.040000	0.050000	0.080000	0.120000
0.6	0.002000	0.003000	0.005000	0.007000	0.010000	0.015000	0.020000	0.030000	0.040000	0.060000	0.080000	0.100000	0.160000	0.240000
0.3	0.004000	0.006000	0.010000	0.014000	0.020000	0.030000	0.040000	0.060000	0.080000	0.120000	0.160000	0.200000	0.320000	0.480000

Table 3: Wh/Pulse Factor

Voltage	4.6	2.3	1.2	0.6	0.3
600	0.0625	0.1250	0.2500	0.5000	1.0000
480	0.0500	0.1000	0.2000	0.4000	0.8000
240	0.0250	0.0500	0.1000	0.2000	0.4000
120	0.0125	0.0250	0.0500	0.1000	0.2000

Table 4: Actual Pulse rates

Switch Setting	Actual Rate	Max Sec./Pulse
4.6	4.6188	0.216
2.3	2.3094	0.433
1.2	1.1547	0.866
0.6	0.57735	1.732
0.3	0.288675	3.464

# INSTALLATION ALTERNATIVES

## SINGLE PHASE INSTALLATION ON THREE-PHASE BALANCED LOADS

Install one CT (must be on phase A current connection) and connect all three voltage leads to A, B, and C voltage connections. Jumper current inputs B and C (see drawing below). If this option is selected, the calculations for kW demand are as follows:

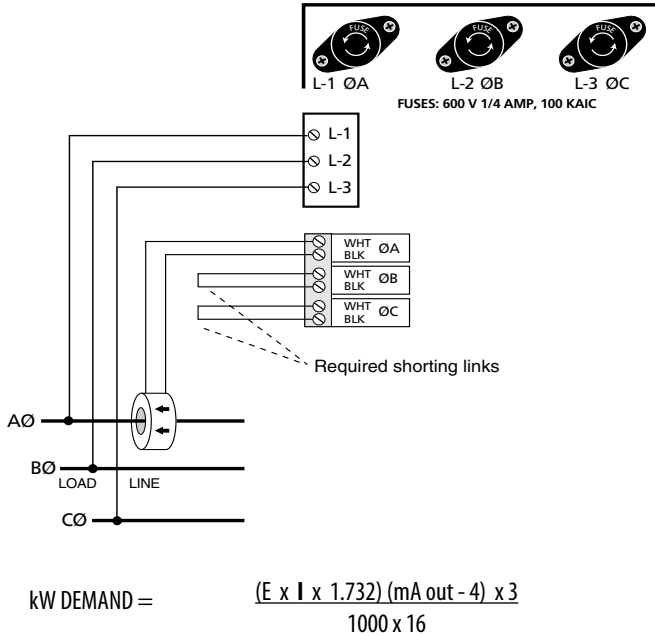

**NOTE:** When the voltage selection switch is in the 208/240 position, always use 240 for the calculation.

### FORMULA DESIGNATIONS

- E** = Line to Line Voltage selected on meter
- I** = Maximum rated full-scale of one CT in amps
- mA out** = 4 to 20 mA reading (supply DC source)

**NOTE:** One pulse is both a rising and falling edge e.g.

## SINGLE PHASE VOLTAGE WITH A NEUTRAL

(e.g., 120 V), the following installation instructions apply (see drawing below):

Install a CT on the "hot" lead per the installation instructions (i.e., arrows facing the load) and connect the "hot" leads from the CT to phase A current input. Connect the voltage input from the "hot" lead to phase A voltage input and the voltage from the neutral to the phase B voltage input. Jumper current inputs B and C. If this method is used, the calculation for kW demand is as follows:

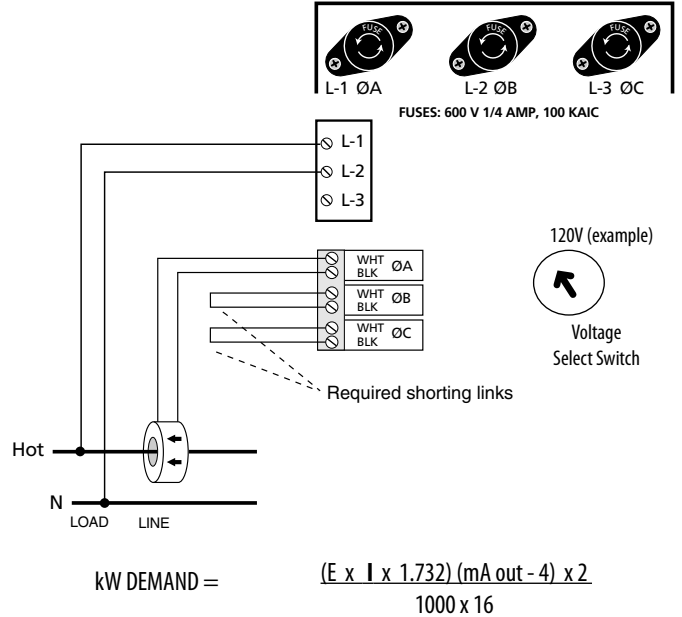

## 240V, 3 WIRE, SINGLE PHASE

Install as previously indicated, jumper phase C voltage input.

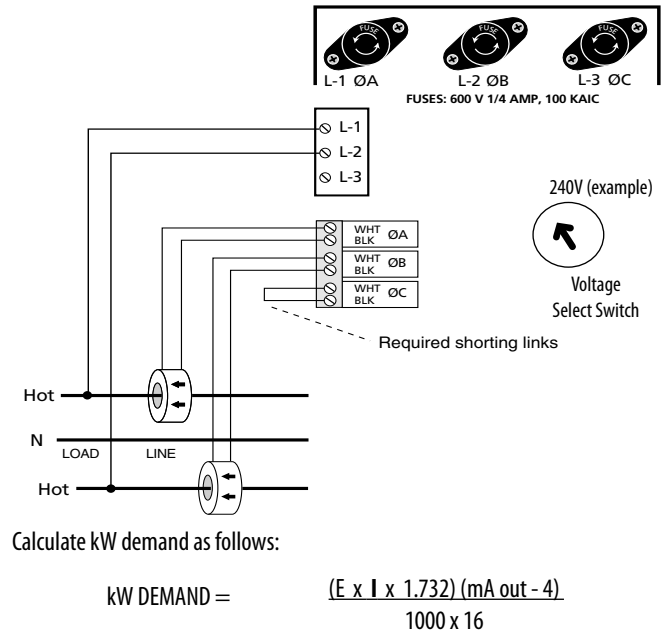

# OPTIONAL POTENTIAL TRANSFORMERS

For use with line voltages in excess of 600V

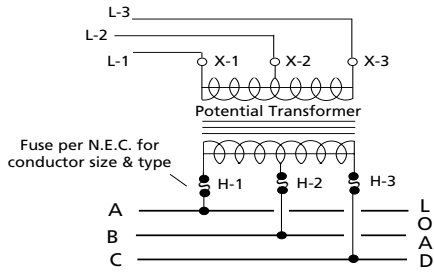

**Option #1:** Using one open delta three phase potential transformer with 120 VAC secondary

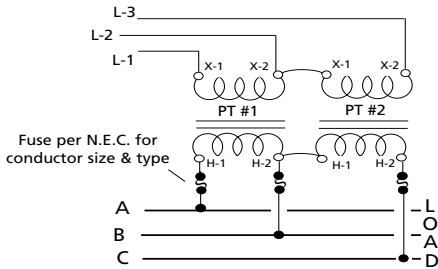

**Option #2:** Using two single phase potential transformers connected open delta.

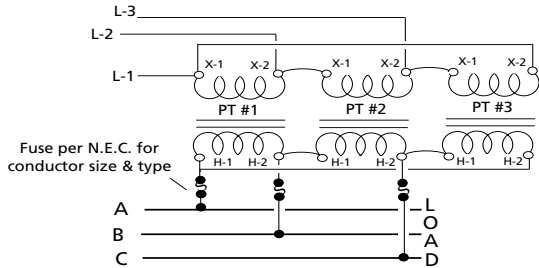

**Option #3** Using three single phase potential transformers delta connected

# OPTIONAL MONITORING OF MULTIPLE LOADS

The Veris 6001 is extremely flexible and allows multiple sets of current sensors to be used in parallel so that multiple locations can be monitored by a single meter. This allows for a totaled output from two or more locations.

## Rules For Accurate Parallel Installation

1. Current sensors must be installed in complete sets of three (3) when used for paralleling. This is necessary when paralleling poly- with single-phase sources.
2. All parallel current sensors must be of the same rating (e.g., all 100A).
3. All locations being monitored must have the same power source. Even with identical voltages, you must not violate this rule.
4. The outputs registered by the kW meter (i.e., the 4-20mA scale, kWh/pulse, and any displays) must be multiplied by the number of CT sets. (e.g., if your kWh/pulse value is 0.5 kWh/pulse with only one set of CTs, then with three sets your new kWh per pulse =  $0.5 \times 3 = 1.5$ ).

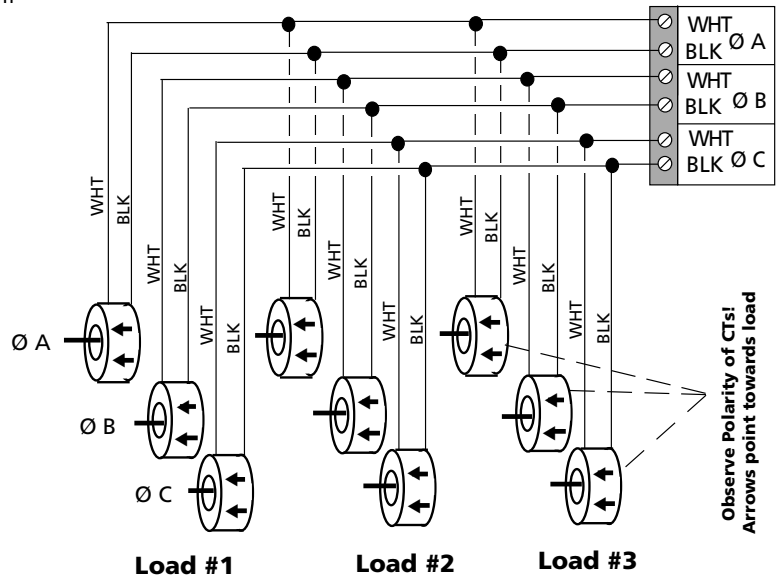

**Paralleling Current Sensors**  
See "Rules" Above

## CURRENT TRANSFORMER SPECIFICATIONS

(Veris H681x Series recommended up to 600VAC)

Output at full-scale ..... 1.0 VAC  
 Accuracy.....  $\pm 1\%$  from 10% to 100% of rating  
 Leads..... 18 AWG 600VAC TEW/TW (UL 1015)Blk/White  
 twisted pair, 30 ft. max. length



**WARNING:** Interface H6000 Series transducers with current mode (0-5A) CTs **ONLY** by using H-6902B interface modules. Failure to properly interface current mode CTs will damage transducer and CTs. Hazardous voltages may result.

## OPTIONAL kW & kWh DISPLAYS

### KWH PULSE COUNT DISPLAY

The kWh display is wired as shown in the wiring diagram.

There are two options for resetting the kWh pulse count display. A jumper is provided on the backside of the LCD display. The front red push button may be enabled or disabled with the jumper. When disabled, the display may only be reset using the black reset switch near the jumper. This feature is useful for tenant submetering to prevent tampering.

***The LCD display counts kWh pulses. The number of pulses must be multiplied by the kWh per pulse to give the true value. Choose the multiplier label provided for your kWh/pulse as previously calculated, and apply to face of the unit.***

### KW DISPLAY

The kW display is wired as shown in the wiring diagram.

Observe polarity. The display is factory calibrated for your voltage/CT size specified. Should a change in application require a different calibration, please consult factory for assistance.

## TRANSDUCER SPECIFICATIONS

Amperage Input ..... Use 1.0 V Safe CTs ONLY. Consult factory for 0-5A CT interface (H-6902B)  
 Voltage range (field selectable)..... 120, 208/240, 480 or 600 VAC  
 Isolation..... 2500 VAC rms  
 Analog output..... 4-20 mA  
 Pulse output..... N.O., Opto FET, 100 mA @ 24VAC/DC. (N.C. available, consult factory)  
 Pulse rate..... Field selectable (nominal 0.3, 0.6, 1.2, 2.3, or 4.6 KWH/pulse)  
 Phase loss output ..... N.C., Opto FET, 100 mA @ 24VAC/DC  
 Low voltage alarm trip point..... 75% to 95%  
 Sealing ..... NEMA 1, 12, 13  
 Temperature range ..... -15° to 40° C  
 Humidity range ..... 0-95% non-condensing  
 Enclosure dimensions ..... (L x W x D).....9.50 " x 8.25" x 4.0"  
 Enclosure construction ..... Steel, NEMA type 1, 3/4" & 1/2" conduit knock outs, hinged door with hasp